



ORIGINAL - NOT TO BE REMOVED FROM OFFICE OF

CT 1726 0149 F



Transfer D234486

WESTERN

AUSTRALIA



Volume 6 Folio 323A

VOL. VOL.

1726 149

# CERTIFICATE OF TITLE

UNDER THE "TRANSFER OF LAND ACT, 1893" AS AMENDED

I certify that the person described in the First Schedule hereto is the registered proprietor of the undermentioned estate in the undermentioned land subject to the easements and encumbrances shown in the Second Schedule hereto.

Page 1 (of 2 pages) 1726 149  
VOL. FOL.

Dated 18th April 1986

*N. J. Smyth*

REGISTRAR OF TITLES



## ESTATE AND LAND REFERRED TO

Estate in fee simple in portion of each of Mount Helena Lots 64 and 65 and being Lot 162 on Plan 5229, delineated on the map in the Third Schedule hereto, limited however to the natural surface and therefrom to a depth of 60.96 metres.

## FIRST SCHEDULE (continued overleaf)

~~Graeme Trevor Wardell-Johnson, Truck Driver, and Yvonne Kay Wardell-Johnson, Home Duties, both of 6 Detling Court, Kelmscott, as joint tenants.~~



## SECOND SCHEDULE (continued overleaf)

- MORTGAGE D234487 to Perth Building Society, Registered 18.4.86 at 3.04 o.e.  
Discharged F351817 1.11.93



*N. J. Smyth*

REGISTRAR OF TITLES

## THIRD SCHEDULE

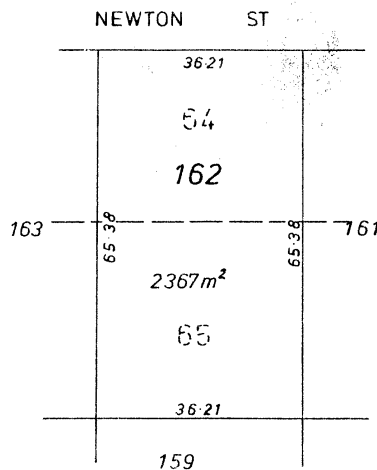

SCALE 1:1000  
m.e.

NOTE: RULING THROUGH AND SEALING WITH THE OFFICE SEAL INDICATES THAT AN ENTRY NO LONGER HAS EFFECT. ENTRIES NOT RULED THROUGH MAY BE AFFECTED BY SUBSEQUENT ENDORSEMENTS.

72009/12/77-45M-S/2860

PERSONS ARE CAUTIONED AGAINST ALTERING OR ADDING TO THIS CERTIFICATE OR ANY NOTIFICATION HEREON

Superseded - Copy for Sketch Only

